

# iCOLOR FLEX SLX

POWERED BY CHROMACORE®



Color Kinetics® iColor® Flex SLX is a flexible LED string lighting solution that is brighter and larger than the iColor Flex SL. iColor Flex SLX is an excellent choice for use in the millwork, signage, and amusement industries. Designed for accent or perimeter lighting or as a component of a custom fixture, iColor Flex SLX provides lighting professionals with a "building block" for the design and creation of custom applications. Uses may include: curtain walls, lined building facades, and under-cabinet lighting. Depending on the iColor Flex SLX application selected, you can create custom color changing effects or custom animation. iColor Flex SLX may be used as a traditional string light or can be custom mounted with the optional mounting clips or mounting tracks.

iColor Flex SLX is a strand of 50 individually-addressable LED nodes driven by Color Kinetics' Chromasic® technology. This dynamic integration of power, communication, and control gives the lighting designer extraordinary color flexibility. LEDs are addressed and powered through Chromasic technology—a Chromacore® embedded microchip on every node. Thus, each node can generate virtually any color at any specified time. Node lenses are available in two models; flat and clear, or domed and translucent. Nodes are mounted in small plastic housings and are arrayed in 4 or 12-inch (0.1 or 0.305 m) increments along a three-wire 16 AWG cable. An integral 50-foot (15.2 m) leader runs from the power/data supply to the first node. Standard colors for iColor Flex SLX are white or black. (Custom node spacing schemes and node color options are available by special order.)

iColor Flex SLX receives power and data from a dedicated Color Kinetics 12V Chromasic power/data supply—available with Ethernet control, DMX512 control, or pre-programmed effects. Each power/data supply supports one 50-node strand. The compact size allows for discrete installation.

## iCOLOR FLEX SLX SPECIFICATIONS

<b>COLOR RANGE</b>	64 billion (36-bit) additive RGB colors; continuously variable intensity
<b>SOURCE</b>	50 Nodes; each with 3 Red, 2 Green, 2 Blue LEDs— 350 LEDs total
<b>AVAILABLE IN</b>	Clear flat lens or Translucent domed lens
<b>HOUSING</b>	Polycarbonate, approx. 1.10" x 1.22" x .56"H (2.97 cm x 3.12 cm x 1.4 cm)
<b>LISTINGS</b>	C-UL US, CE

## COMMUNICATION SPECIFICATIONS

<b>DATA INTERFACE</b>	Color Kinetics data interface system
<b>CONTROL</b>	Ethernet, DMX512 or stand-alone

## ELECTRICAL SPECIFICATIONS (LIGHTS)

<b>POWER REQUIREMENT</b>	12VDC
<b>POWER CONSUMPTION</b>	50W Max. at full intensity (full RGB), per 50 node strand
<b>POWER SUPPLY</b>	Color Kinetics PDS-60Ca 12V (Preprogrammed 109-000020-00, DMX 109-000020-01, and Ethernet 109-000020-02)

## ELECTRICAL SPECIFICATIONS (POWER/DATA SUPPLY)

<b>POWER INPUT</b>	100VAC to 240VAC auto ranging (50Hz–60Hz) Power factor correction (PFC)
<b>POWER OUTPUT</b>	12VDC
<b>HEAT DISSIPATION</b>	25 percent of total power output
<b>HOUSING</b>	NEMA 4 indoor/outdoor rated enclosure
<b>CONNECTORS</b>	Data: RJ45 input/output connectors Power: 4-pin connector

## ENVIRONMENTAL SPECIFICATIONS

<b>TEMPERATURE RANGE</b>	-40°F to 122°F (-40°C to 50°C) operating temperature -4°F to 122°F (-20°C to 50°C) starting temperature
<b>PROTECTION RATING</b>	IP66

## LED SOURCE LIFE

In traditional lamp sources, lifetime is defined as the point at which 50% of the lamps fail. This is also termed Mean Time Between Failure [MTBF]. LEDs are semiconductor devices and have a much longer MTBF than conventional sources. However, MTBF is not the only consideration in determining useful life. Color Kinetics uses the concept of useful light output for rating source lifetimes. Like traditional sources, LED output degrades over time (lumen depreciation) and this is the metric for SSL lifetime.

LED lumen depreciation is affected by numerous environmental conditions such as ambient temperature, humidity, and ventilation. Lumen depreciation is also affected by means of control, thermal management, current levels, and a host of other electrical design considerations. Color Kinetics systems are expertly engineered to optimize LED life when used under normal operating conditions. Lumen depreciation information is based on LED manufacturers' source life data as well as other third party testing. Low temperatures and controlled effects have a beneficial effect on lumen depreciation. Overall system lifetime could vary substantially based on usage and the environment in which the system is installed.

Temperature and effects will affect lifetime. Color Kinetics rates product lifetime using lumen depreciation to 50% of original light output. When the fixture is running at room temperature using a color wash effect, the range of lifetime is in the range of 30,000-50,000 hours. This is LED manufacturers' test data. For more detailed information on source life, please see [www.colorkinetics.com/lifetime](http://www.colorkinetics.com/lifetime).

**CHROMACORE®**  
BY COLOR KINETICS

**CHROMASIC™**  
BY COLOR KINETICS

**OPTIBIN®**  
BY COLOR KINETICS

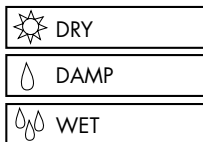

### iColor Flex SLX ITEM#

- 101-000053-00 (4" White, Translucent Dome)
- 101-000053-01 (4" White, Clear Flat)
- 101-000054-00 (12" White, Translucent Dome)
- 101-000054-01 (12" White, Clear Flat)
- 101-000055-00 (4" Black, Translucent Dome)
- 101-000055-01 (4" Black, Clear Flat)
- 101-000056-00 (12" Black, Translucent Dome)
- 101-000056-01 (12" Black, Clear Flat)

This product is protected by one or more of the following patents: U.S. Patent Nos. 6,016,038, 6,150,774 and other patents listed at <http://colorkinetics.com/patents/>. Other patents pending.

©2005-2006 Color Kinetics Incorporated. All rights reserved. Chromacore, Chromasic, Color Kinetics, the Color Kinetics logo, ColorBlast, ColorBlaze, ColorBurst, ColorCast, ColorPlay, ColorScape, Direct Light, iColor, iColor Cove, iPlayer, Optibin, Powercore, QuickPlay, Sauce, the Sauce logo, and SmartJuice are registered trademarks and DIMand, EssentialWhite, IntelliWhite, and Light Without Limits are trademarks of Color Kinetics Incorporated.

All other brand or product names are trademarks or registered trademarks of their respective owners.

BR0165 Rev 02

Specifications subject to change without notice. Refer to [www.colorkinetics.com](http://www.colorkinetics.com) for the most recent data sheet versions.

# iCOLOR FLEX SLX - CLEAR FLAT LENS

## PHOTOMETRIC PERFORMANCE

Photometric data is for the LED package, provided by the manufacturer, and the distributions do not reflect the housing and lens.

### SOURCE SPECIFICATIONS

View Angle: 115°  
 Distribution: Symmetric direct illumination

### ILLUMINANCE DISTRIBUTION

0.2 2.2	0.3 3.2	0.4 4.3	0.5 5.4	0.3 3.2	0.2 2.2	3.0'/1.0m
0.3 3.2	0.6 6.5	0.9 9.7	0.9 9.7	0.6 6.5	0.3 3.2	2.0'/0.6m
0.5 5.4	0.9 9.7	1.4 15.1	1.3 14.0	0.9 9.7	0.5 5.4	1.0'/0.3m
0.4 4.3	0.9 9.7	1.3 14.0	1.4 15.1	0.9 9.7	0.4 4.3	1.0'/0.3m
0.3 3.2	0.6 6.5	0.9 9.7	0.9 9.7	0.6 6.5	0.3 3.2	2.0'/0.6m
0.2 2.2	0.3 3.2	0.4 4.3	0.5 5.4	0.3 3.2	0.2 2.2	3.0'/1.0m
3.0'/1.0m	0'/0m	3.0'/1.0m		3.0'/1.0m		

Units: Footcandles (top)/Lux (bottom)  
 10.8 lux = 1 fc  
 Measured on: All, reflectance model 50%  
 Distance from surface: Centered 1' (0.3 m) from, and perpendicular to, surface

### CANDLE POWER DISTRIBUTION

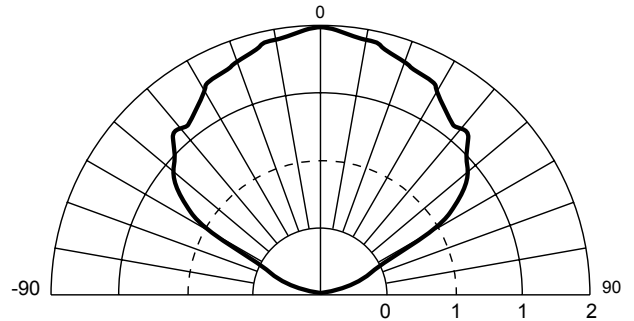

Measured on: White  
 Beam center: 1.91 cd  
 Thin dashed lined: Indicates 50% of peak  
 Multipliers: 0.42 Red, 0.50 Green, 0.08 Blue

### ILLUMINANCE

COLOR	1' 0.3m	2' 0.6m	4' 1.2m	6' 2m
WHITE	4.9 52.7	0.7 7.5	0.0 0.1	0.1 1.1
RED	2.1 22.2	0.3 3.2	0.0 0.0	0.0 0.5
GREEN	2.5 26.4	0.4 3.8	0.0 0.1	0.1 0.5
BLUE	0.4 4.2	0.1 0.6	0.0 0.0	0.0 0.1

Measured in Footcandles (top)/Lux (bottom) on axis.  
 Measured on: All, reflectance 0.

### LIGHT OUTPUT

COLOR	TOTAL OUTPUT (lumens)	POWER (Watts)	EFFICACY (Lm/w)
WHITE	5.4	1.0	5.6
RED	2.3	0.3	7.6
GREEN	2.7	0.3	9.0
BLUE	0.4	0.3	1.4

# iCOLOR FLEX SLX

## PHYSICAL DIMENSIONS

### iColor Flex SLX

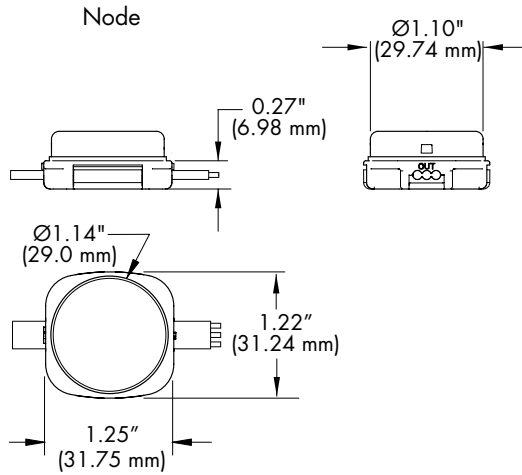

### Lens Options

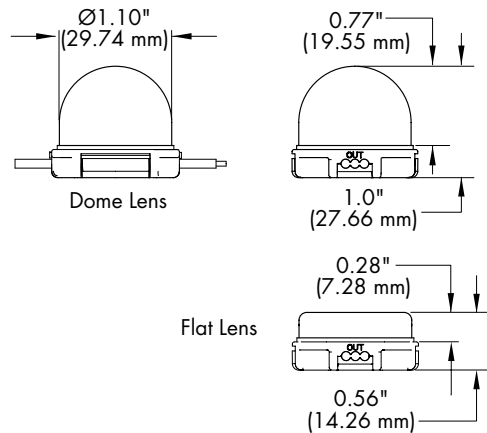

### Mounting Accessories

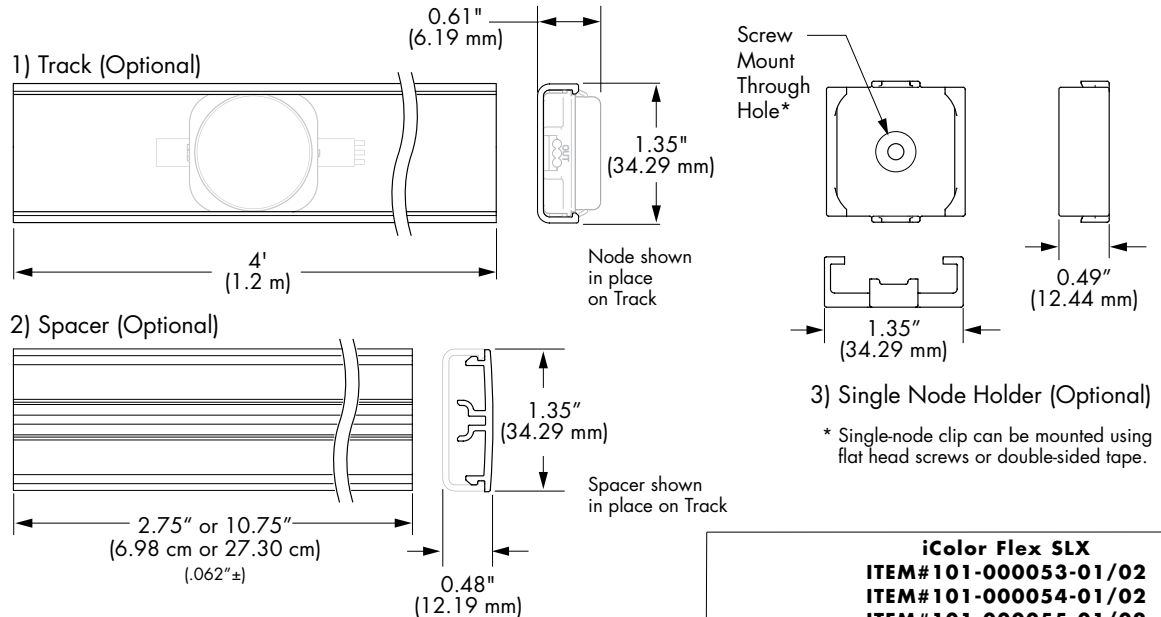

\* Single-node clip can be mounted using flat head screws or double-sided tape.

iColor Flex SLX	
ITEM# 101-000053-01/02	
ITEM# 101-000054-01/02	
ITEM# 101-000055-01/02	
ITEM# 101-000056-01/02	
POWER CONNECTION	3-wire, 16AWG power/data cable
POWER REQUIREMENT	12VDC (50W)
LENGTH	4" (10 cm) increment 67 ft (20.4 m) 12" (30.5 cm) increment 100 ft (30.5 m)
WEIGHT RANGE	≈ 4.6 lbs (2.1 kg)

### OPTIBIN®

There are inherent variations in the fabrication processes of all semiconductor materials. For LEDs, this variance results in differences in the color and intensity of light output as well as electrical characteristics. Due to these differences, LED manufacturers sort production into "bins," but insuring the availability of a single bin is very difficult. To minimize this issue and achieve optimal color consistency in its products, Color Kinetics has developed and uses a proprietary technology called Optibin. Optibin is an advanced production binning optimization process that minimizes the effects of LED variance for the best possible output uniformity in the final product. Color Kinetics Optibin technology gives the most consistent control of color and intensity from product to product.

# iCOLOR FLEX SLX

## FUNCTIONAL FLOW DIAGRAM

Maximum: 1 iColor Flex SLX run (50 nodes) per PDS-60ca 12V on Output 1  
 Leader Cable: 50-feet (15 m)

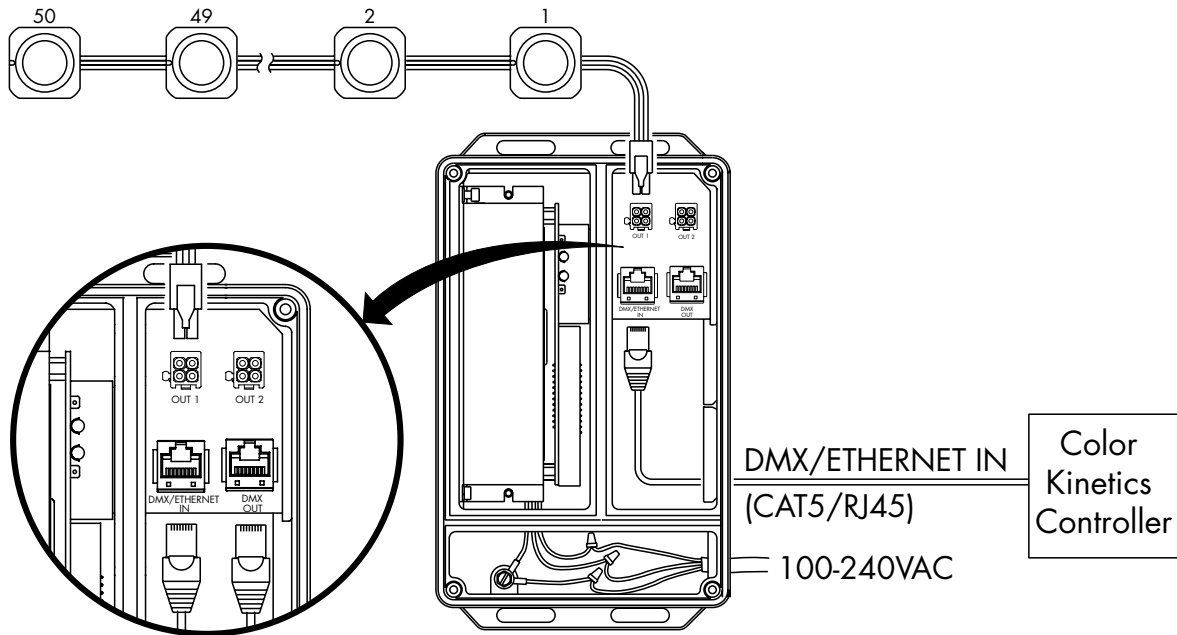

For complete installation instructions and safety precautions, refer to the iColor Flex SLX User Guide and wiring diagrams located at [www.colorkinetics.com/support](http://www.colorkinetics.com/support).

### Additional Items

<b>POWER/DATA SUPPLY</b>	PDS-60ca 12V (109-000020-00/01/02)
<b>CONTROLLERS</b>	Light System Manager (103-000015-00) iPlayer® 2 (103-000007-00/01) Video System Manager (103-000018-01)