

iW PROFILE g2

An INTELLIWHITE™ Product



The iW Profile g2 fixture is a low-profile, linear 12" (30.2 cm) system that features higher light output and enhanced light quality with new optics and advanced LEDs (as compared to the previous generation). The linear design and fixture-to-fixture color consistency of this high-quality white light is well suited for display, museum, exhibit, retail, hospitality and architectural applications.

iW Profile g2 provides flexible color temperature and brightness control through Chromacore® technology, the proven approach that underlies Color Kinetics' existing intelligent solid-state lighting systems. When applied to IntelliWhite™ products, Chromacore controls channels of warm white and cool white LEDs to produce color temperatures within the range of 3000–6500 Kelvin from within a single fixture. iW Profile g2 allows the adjustment of light intensity while providing the option to either maintain or vary the color temperature.

iW Profile g2 is available with three different beam angles to meet diverse application demands: narrow, medium, and forward-throw asymmetric. iW Profile g2 is rated for indoor and damp location installations. The end-to-end locking connectors, capable of making 180° turns, make iW Profile g2 extremely versatile and easily adaptable to even the most challenging mounting environments.

iW Profile g2 is track mounted using the provided eight inch long 0°/60° track or 45° track for forward-throw asymmetric fixtures. This track allows for a light aim perpendicular to the mounting surface, angled at 60° from center, or angled at 45° from center. Optional 5 1/2 foot tracks are available for long, linear runs of 0°/45°/60° mounting angles.

iW PROFILE g2 SPECIFICATIONS

COLOR TEMP RANGE	3000K to 6500K
SOURCE	High intensity LEDs
BEAM ANGLE	Narrow, Medium, Forward-Throw Asymmetric
HOUSING	Aluminum with enamel finish
LENS	Clear tempered UV resistant lens
CONNECTORS	Unified power and data cable
LISTINGS	UL/cUL, CE

COMMUNICATIONS SPECIFICATIONS

DATA INTERFACE	Color Kinetics iW PDS-150 or iW PDS-60
CONTROL	Color Kinetics Line of Controllers, including iW Scene Controller, or LSM*

ELECTRICAL SPECIFICATIONS

POWER REQUIREMENT	24VDC
POWER CONSUMPTION	15W

ENVIRONMENTAL SPECIFICATIONS

TEMPERATURE RANGE	-4°F to 122°F (-20°C to 50°C) based on testing of specific product
PROTECTION RATING	IP60 (top of housing); IP50 (bottom of housing)

* For large or complex installations, consider controlling iW Profile g2 with Light System Manager (LSM). Refer to the LSM data sheets or contact support@colorkinetics.com for more information.

CHROMACORE®
BY COLOR KINETICS

OPTIBIN®
BY COLOR KINETICS



ITEM# 501-000010-00 (Medium)
501-000010-01 (Narrow)
501-000010-02 (Forward-Throw Asymmetric)

This product is protected by one or more of the following patents:
U.S. Patent Nos. 6,016,038, 6,150,774 and other patents listed at
<http://colorkinetics.com/patents/>. Other patents pending.

©2006 Color Kinetics Incorporated. All rights reserved.

Chromacore, Chromasic, Color Kinetics, the Color Kinetics logo, ColorBlast, ColorBlaze, ColorBurst, ColorCast, ColorPlay, ColorScape, Direct Light, iColor, iColor Cove, iPlayer, Optibin, Powercore, QuickPlay, Sauce, the Sauce logo, and Smartjuice are registered trademarks and DIMand, EssentialWhite, eW, IntelliWhite, iW, and Light Without Limits are trademarks of Color Kinetics Incorporated. All other brand or product names are trademarks or registered trademarks of their respective owners.

BRO185 Rev 04

Specifications subject to change without notice. Refer to www.colorkinetics.com for the most recent data sheet versions.

LED SOURCE LIFE

In traditional lamp sources, lifetime is defined as the point at which 50% of the lamps fail. This is also termed Mean Time Between Failure [MTBF]. LEDs are semiconductor devices and have a much longer MTBF than conventional sources. However, MTBF is not the only consideration in determining useful life. Color Kinetics uses the concept of useful light output for rating source lifetimes. Like traditional sources, LED output degrades over time (lumen depreciation) and this is the metric for SSL lifetime.

LED lumen depreciation is affected by numerous environmental conditions such as ambient temperature, humidity, and ventilation. Lumen depreciation is also affected by means of control, thermal management, current levels, and a host of other electrical design considerations. Color Kinetics systems are expertly engineered to optimize LED life when used under normal operating conditions. Lumen depreciation information is based on LED manufacturers' source life data as well as other third party testing. Low temperatures and controlled effects have a beneficial effect on lumen depreciation. Overall system lifetime could vary substantially based on usage and the environment in which the system is installed.

Temperature and effects will affect lifetime. Color Kinetics rates product lifetime using lumen depreciation to 70% of original light output. When the fixture is running on warm or cool, at room temperature, the LED lifetime is in the range of 50,000 – 70,000 hours. This is based on LED manufacturers' test data. High output is defined as any LED device that is 1/2 watt or above. For more detailed information on source life, please see www.colorkinetics.com/lifetime.

iW PROFILE g2 - NARROW

PHOTOMETRIC PERFORMANCE

SOURCE SPECIFICATIONS

Lens:	UV-resistant soft-focus polycarbonate lens
Source:	10 LEDs (5 warm white, 5 cool white)
Beam Angle:	10° X 110° (at 50% of peak illuminance)
Distribution:	Symmetric direct illumination
CRI:	79 All, 73 Warm, 83 Cool

ILLUMINANCE DISTRIBUTION

0.2 2.2	0.2 2.2	0.2 2.2	0.2 2.2	0.2 2.2	0.2 2.2	1.0'/0.3m
0.5 5.4	3.9 42.0	6.9 74.3	3.9 42.0	0.6 6.5	0.2 2.2	2.0'/0.6m
0.9 9.7	7.7 82.9	17.1 184.1	14.0 150.7	4.5 48.4	0.6 6.5	3.0'/1.0m
0.6 6.5	4.5 48.4	14.0 150.7	17.1 184.1	7.7 82.9	0.9 9.7	4.0'/1.2m
0.2 2.2	0.6 6.5	3.9 42.0	6.9 74.3	3.9 42.0	0.5 5.4	5.0'/1.5m
0.2 2.2	0.2 2.2	0.2 2.2	0.2 2.2	0.2 2.2	0.2 2.2	6.0'/2.0m
3.0'/1.0m		0'/0m		3.0'/1.0m		

Units: Footcandles (top)/Lux (bottom)
10.8 lux = 1 fc

Location: Centered 1'/0.3m from, and perpendicular to, surface

Measured on: All, Reflectance 50%

ILLUMINANCE

	3' 1m	6' 2m	9' 3m	15' 5m
ALL	19.7 212.1	4.3 46.3	1.8 19.4	0.6 6.5

Measured in Footcandles (top)/Lux (bottom).
Measured on all, reflectance 0.

CRI

It is common practice in the lighting industry to use color rendering index (CRI) to compare the properties of various light sources. There are known deficiencies and limitations associated with CRI and as a result, it is not always an accurate indicator of good object color appearance. This is especially true for LED-based sources. Until a better method for measuring color rendering in LEDs is accepted, Color Kinetics measures CRI in accordance with the current CIE 13.3-1995 standard using the Ra calculation. The reference illuminants employed are the Planckian locus below 5000K and CIE Daylight reference above 5000K. All measurements for Color Kinetics products are performed by third party laboratories using NIST-traceable instruments.

CANDLE POWER DISTRIBUTION

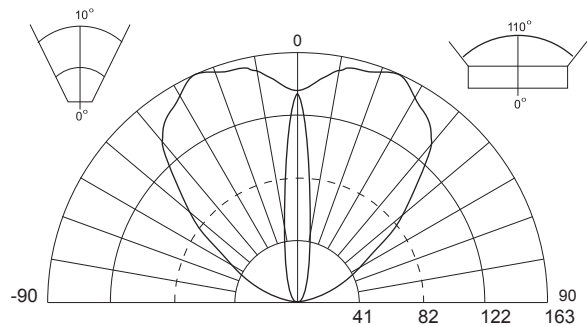

Measured on: All
Beam peak: 163 cd
Thin dashed line: Indicates 50% of peak

LIGHT OUTPUT

	TOTAL OUTPUT (lumens)	POWER (Watts)	EFFICACY (lm/W)
ALL	118	12.0	9.8
WARM	107	11.8	9.1
COOL	118	11.8	10.0

Note: Efficacy figures are for a complete tested fixture not simply a lamp source.

iW PROFILE g2 - MEDIUM

PHOTOMETRIC PERFORMANCE

SOURCE SPECIFICATIONS

Lens: UV-resistant soft-focus polycarbonate lens
 Source: 10 LEDs (5 warm white, 5 cool white)
 Beam Angle: 50° X 50°
 Distribution: Symmetric direct illumination
 CRI: 79 All, 73 Warm, 83 Cool

ILLUMINANCE DISTRIBUTION

0.2 2.2	0.3 3.2	0.3 3.2	0.3 3.2	0.3 3.2	0.2 2.2	1.0'/0.3m
0.3 3.2	3.9 42.0	7.4 79.7	4.0 43.1	0.4 4.3	0.2 2.2	2.0'/0.6m
0.3 3.2	7.4 79.7	17.9 192.7	14.5 156.1	4.0 43.1	0.3 3.2	3.0'/1.0m
0.3 3.2	4.0 43.1	14.5 156.1	17.9 192.7	7.4 79.7	0.3 3.2	4.0'/1.2m
0.2 2.2	0.4 4.3	4.0 43.1	7.4 79.7	3.9 42.0	0.3 3.2	5.0'/1.5m
0.2 2.2	0.2 2.2	0.3 3.2	0.3 3.2	0.3 3.2	0.2 2.2	6.0'/2.0m
3.0'/1.0m		0'/0m		3.0'/1.0m		

Units: Footcandles (top)/Lux (bottom)
 10.8 lux = 1 fc

Location: Centered 1'/0.3m from, and perpendicular to, surface
 Measured on: All, Reflectance 50%

ILLUMINANCE

	3' 1m	6' 2m	9' 3m	15' 5m
ALL	18.3 197.0	4.0 43.1	1.7 18.3	0.6 6.5

Measured in Footcandles (top)/Lux (bottom).
 Measured on all, reflectance 0.

CRI

It is common practice in the lighting industry to use color rendering index (CRI) to compare the properties of various light sources. There are known deficiencies and limitations associated with CRI and as a result, it is not always an accurate indicator of good object color appearance. This is especially true for LED-based sources. Until a better method for measuring color rendering in LEDs is accepted, Color Kinetics measures CRI in accordance with the current CIE 13.3-1995 standard using the Ra calculation. The reference illuminants employed are the Planckian locus below 5000K and CIE Daylight reference above 5000K. All measurements for Color Kinetics products are performed by third party laboratories using NIST-traceable instruments.

CANDLE POWER DISTRIBUTION

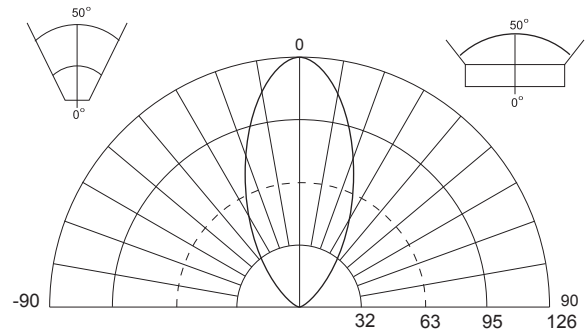

Measured on: All
 Beam peak: 126 cd
 Thin dashed line: Indicates 50% of peak

LIGHT OUTPUT

	TOTAL OUTPUT (lumens)	POWER (Watts)	EFFICACY (lm/W)
ALL	120	12.0	10.0
WARM	102	11.8	8.6
COOL	127	11.8	10.8

Note: Efficacy figures are for a complete tested fixture not simply a lamp source.

iW PROFILE g2 - ASYMMETRIC

PHOTOMETRIC PERFORMANCE

SOURCE SPECIFICATIONS

Lens: UV-resistant soft-focus polycarbonate lens
 Source: 10 LEDs (5 warm white, 5 cool white)
 Beam Angle: 20° X 40° X 100°
 Distribution: Asymmetric direct illumination
 CRI: 79 All, 73 Warm, 84 Cool

CANDLE POWER DISTRIBUTION

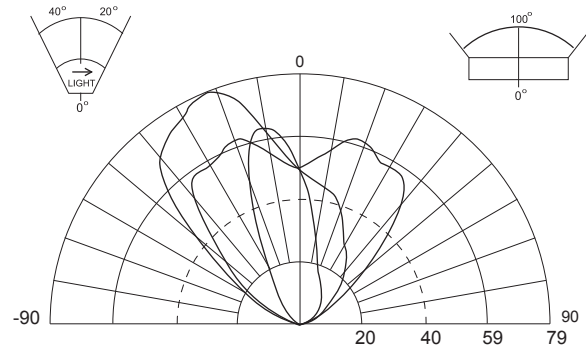

Measured on: All
 Beam center: 79 cd
 Thin dashed line: Indicates 50% of peak

LIGHT OUTPUT

	TOTAL OUTPUT (lumens)	POWER (Watts)	EFFICACY (Lm/w)
ALL	100	12.0	8.3
WARM	90	11.8	7.6
COOL	101	11.8	8.6

Note: Efficacy figures are for a complete tested fixture not simply a lamp source.

ILLUMINANCE DISTRIBUTION

0.2 2.2	0.3 3.2	0.4 4.3	0.3 3.2	0.2 2.2	0.2 2.2	1.0'/0.3m
0.3 3.2	2.4 25.8	4.4 47.4	2.6 28.0	0.5 5.4	0.2 2.2	2.0'/0.6m
0.5 5.4	6.2 66.7	13.4 144.2	10.1 108.7	2.7 29.1	0.4 4.3	3.0'/1.0m
0.4 4.3	4.3 46.3	13.2 142.1	15.0 161.5	6.2 66.7	0.5 5.4	4.0'/1.2m
0.2 2.2	0.5 5.4	4.0 43.1	7.4 79.7	4.0 43.1	0.4 4.3	5.0'/1.5m
0.2 2.2	0.2 2.2	0.2 2.2	0.2 2.2	0.2 2.2	0.2 2.2	6.0'/2.0m
3.0'/1.0m	0'/0m				3.0'/1.0m	

Units: Footcandles (top)/Lux (bottom)
 10.8 lux = 1 fc

Location: Centered 1'/0.3m from, and perpendicular to, surface
 Measured on: All, reflectance model 50/%

ILLUMINANCE

	3' 1m	6' 2m	9' 3m	15' 5m
ALL	7.1 76.4	1.5 16.1	0.7 7.5	0.2 2.2

Measured in Footcandles (top)/Lux (bottom).
 Measured on all, reflectance 0.

CRI

It is common practice in the lighting industry to use color rendering index (CRI) to compare the properties of various light sources. There are known deficiencies and limitations associated with CRI and as a result, it is not always an accurate indicator of good object color appearance. This is especially true for LED-based sources. Until a better method for measuring color rendering in LEDs is accepted, Color Kinetics measures CRI in accordance with the current CIE 13.3-1995 standard using the Ra calculation. The reference illuminants employed are the Planckian locus below 5000K and CIE Daylight reference above 5000K. All measurements for Color Kinetics products are performed by third party laboratories using NIST-traceable instruments.

iW PROFILE g2

FUNCTIONAL FLOW DIAGRAM (iW PDS-150)

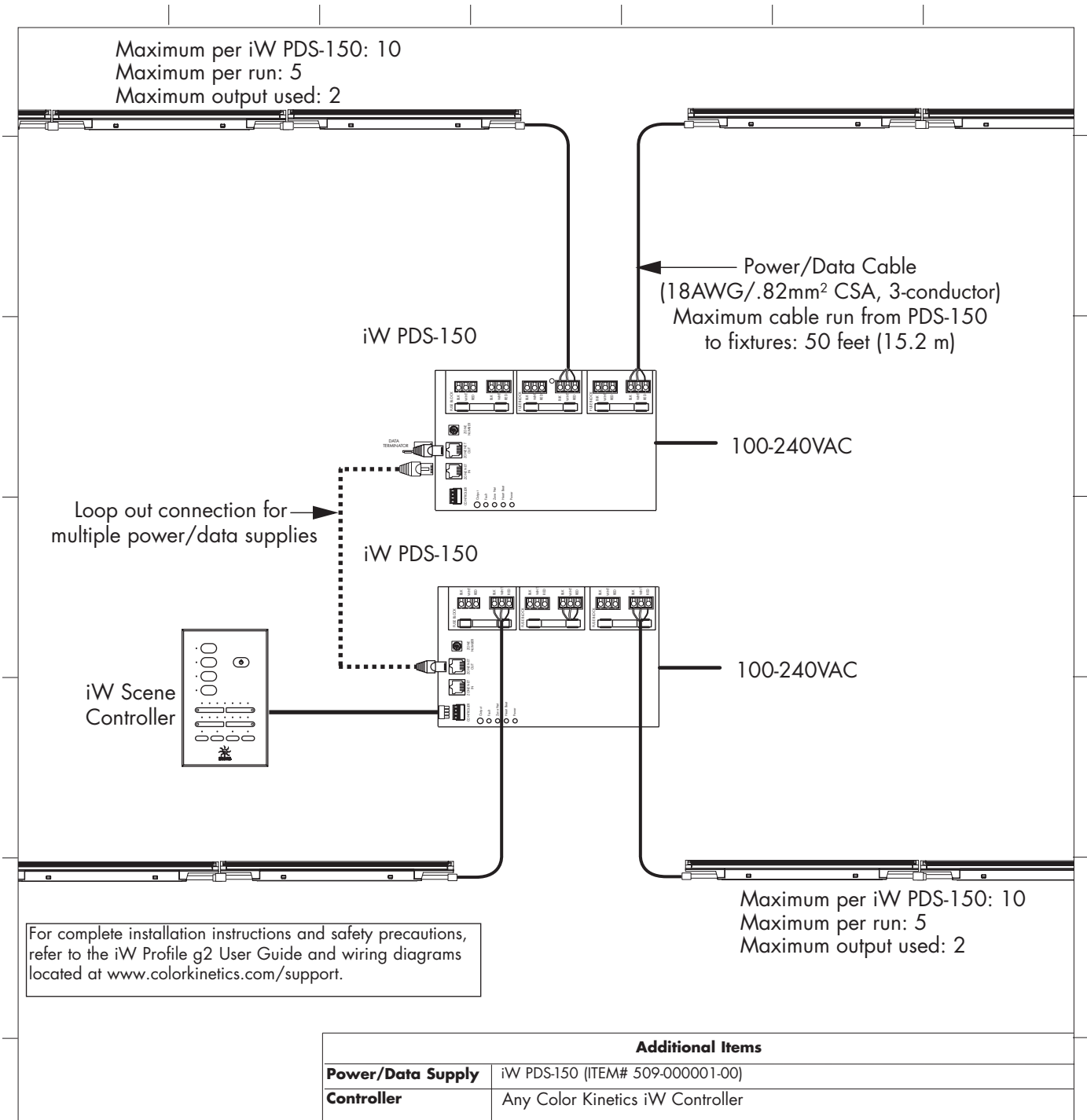

iW PROFILE g2

FUNCTIONAL FLOW DIAGRAM (iW PDS-60)

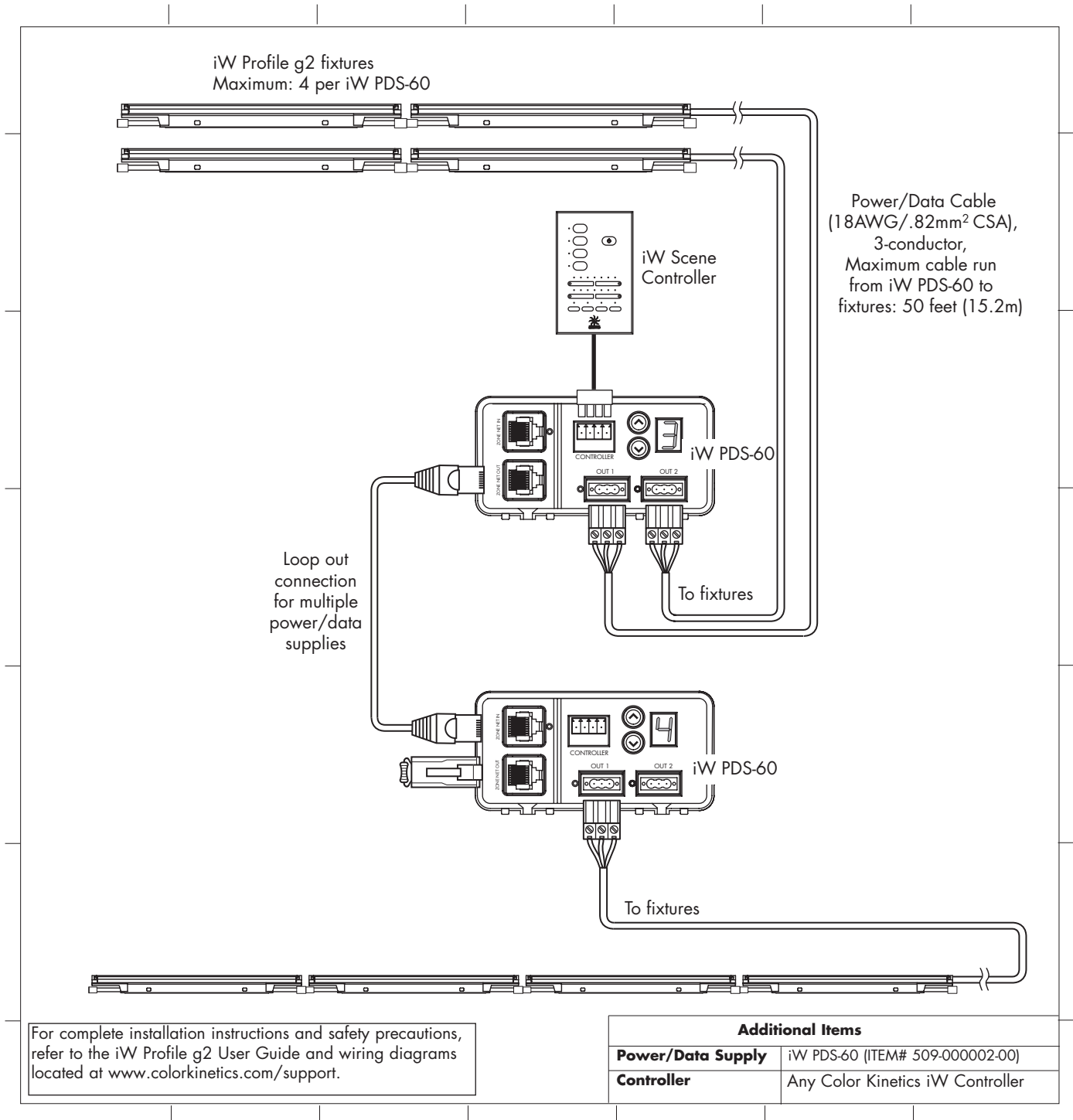

OPTIBIN®

There are inherent variations in the fabrication processes of all semiconductor materials. For LEDs, this variance results in differences in the color and intensity of light output as well as electrical characteristics. Due to these differences, LED manufacturers sort production into "bins," but insuring the availability of a single bin is very difficult. To minimize this issue and achieve optimal color consistency in its products, Color Kinetics has developed and uses a proprietary technology called Optibin. Optibin is an advanced production binning optimization process that minimizes the effects of LED variance for the best possible output uniformity in the final product. Color Kinetics Optibin technology gives you the most consistent control of color and intensity from product to product.