

COLORBLAST 6

USER GUIDE



COLOR KINETICS INCORPORATED
10 MILK STREET, SUITE 1100
BOSTON, MA 02108 USA
TEL 888 FULL RGB
TEL 617 423 9999
FAX 617 423 9998
INFO@COLORKINETICS.COM
WWW.COLORKINETICS.COM

CHROMACORE®
BY COLOR KINETICS

OPTIBIN®
BY COLOR KINETICS

ITEM# 116-000013-00 (White, Frosted)
116-000013-01 (Black, Frosted)
116-000013-02 (White, Clear)
116-000013-03 (Black, Clear)

This product is protected by one or more of the following U.S. Patents and their foreign counterparts: 6,016,038, 6,150,774, 6,292,901, 6,340,868, 6,777,891, 6,788,011, 6,806,659, 6,969,954, and 6,975,079. Other patents pending.

©2002-2007 Color Kinetics Incorporated. All rights reserved. Chromacore, Chromasic, CK, the CK logo, Color Kinetics, the Color Kinetics logo, Color Kinetics The Leader in Intelligent Light, ColorBlast, ColorBlaze, ColorBurst, ColorCast, ColorPlay, ColorScape, DiMand, Direct Light, EssentialWhite, eV, iColor, iColor Cove, IntelliWhite, iW, iPlayer, Light Without Limits, Optibin, Powercore, QuickPlay, Sauce, the Sauce logo, and Smartjuice are either registered trademarks or trademarks of Color Kinetics Incorporated in the United States and/or other countries.

PUB-000143-00 Rev. 03

Specifications subject to change without notice. Refer to www.colorkinetics.com for the most recent version.

INTRODUCTION

Welcome to a more colorful world brought to you by Color Kinetics. Chromacore®, our patented core technology, generates and controls millions of colors and a variety of lighting effects using a microprocessor to control LEDs. This User Guide contains important information about installing and operating your new ColorBlast® 6 fixture safely.

Included In This Box

- ColorBlast 6 with base
- Outdoor junction box gasket for standard US junction boxes
- Water-tight grommet assembly
- 2 8-32 screws for indoor standard US junction boxes with 3.5" center to center mounting holes
- 4 10-24 stainless steel screws for outdoor junction boxes
- Hex key wrench (3/32")
- User Guide

Additional Items Needed

- 4" Electrical junction box (rated for your application) with 3.5" center to center distance for mounting locations
- 24VDC Color Kinetics power/data supply PDS-150e (Item# 109-000008-01) or PDS-60 24V (Item# 109-000017-00/03)
- Controller - Color Kinetics DMX Controller or DMX compatible
- Color Kinetics Zapi (Item# 103-000005-00, US/103-000005-01, EU) or Serial Addressing Software (SAS) with iPlayer 2 or Smart Jack 3
- Adjustable wrench
- Phillips head screw driver

Scope of This User Guide

The goal of this user guide is to explain in an easily understood language the necessary steps to install ColorBlast 6 and assure peak performance. Its intended use is for reference only, by qualified professionals. This document should never be considered a substitute for any provisions of a regulation or state, local and/or national codes.

Identification and Warnings of Safety Hazards

In accordance with ANSI Z535.4 the following system of identifying the severity of the hazards associated with the products is used:

"DANGER" Imminently hazardous situation which, if not avoided, will result in death or serious injury.

"WARNING" Potentially hazardous situation that, if not avoided, could result in death or serious injury.

"CAUTION" Potentially hazardous situation that, if not avoided, may result in minor or moderate injury or property damage.

DANGER: Ensure that the main power supply is off before installing or wiring ColorBlast 6 and the power/data supply. Failure to adhere to these instructions will result in death or serious injury.

WARNING: ColorBlast 6 and the power/data supply must be installed by a qualified professional in accordance with NEC and relevant local codes. Failure to comply can result in death, serious injury, or property damage.

WARNING: Do not attempt to install or use ColorBlast 6 or the power/data supply until you read and understand the installation instructions and safety labels. Failure to adhere to these instructions could result in serious injury or property damage.

CAUTION: ColorBlast 6 has no serviceable parts. Do not attempt to open the fixture. Doing so will result in property damage and void the warranty.

CAUTION: Do not modify, alter, or attempt to service ColorBlast 6. Doing so will void the warranty.

CAUTION: Do not use sharp tools near or on the fixture lens. Doing so will result in property damage and void the warranty.

CAUTION: Do not hot swap. Ensure the power supply is off before connecting or disconnecting fixtures. Hot swapping will result in property damage and void the warranty.

NOTE: The instructions and precautions set forth in this installation guide are not necessarily all-inclusive, all conceivable, or relevant to all applications as Color Kinetics cannot anticipate all conceivable or unique situations.

Owner/User Responsibilities

It is the responsibility of the contractor, installer, purchaser, owner and user to install, maintain, and operate ColorBlast 6 in such a manner as to comply with all state, local, and national laws, ordinances, regulations, and the American National Standard Institute Safety Code.

PLANNING THE INSTALLATION

The nature of a ColorBlast 6 installation requires planning to ensure a timely, successful installation with minimal complications and down time.

Planning Suggestions

When planning a ColorBlast 6 installation, Color Kinetics suggests doing the following:

- Consult an Electrical Inspector to approve all wiring plans.
- Refer to local and state codes for installation compliance.
- Create a Mapping Grid. Use this grid to record serial numbers for easy reference and addressing.
- Create a Layout Plan drawing, per Lighting Designer or Architect.
- Employ Color Kinetics Application Engineering Services.
- Get detailed wiring diagrams and additional support from <http://support.colorkinetics.com>.

Installation Considerations

When creating your installation plan, consider the following:

- Location of power/data supply in relationship to lights.
 - Maximum accumulated cable length for all ColorBlast 6 fixtures connected to a single PDS-150e is 400 feet. Maximum single cable run between PDS-150e and ColorBlast 6 is 150 feet.
 - Maximum cable length for a ColorBlast 6 fixture connected to a PDS-60 24V is 150 feet. Therefore, PDS-60 24V must be located within 150 feet of the furthest supported fixture.
- Location of fixture and method of mounting. ColorBlast 6 can be installed indoors or outdoors on a wall, ceiling, or floor. Junction boxes and mounting methods vary according to location.

INSTALLING COLORBLAST 6 Steps to a Successful Installation

1. Record serial numbers and identify fixtures as you unpack them.
2. Install the power/data supplies.
3. Address the light fixtures.
4. Install ColorBlast 6 fixtures.
5. Make electrical connections.

Recording Serial Numbers

1. As you unpack the fixtures record the serial numbers. Each ColorBlast 6 has a unique serial number programmed at the time of manufacture.
2. Write the serial numbers onto a Mapping Grid or use a bar code scanner along with Color Kinetics Serial Addressing Software (SAS) to record each serial number. SAS and instructions are located at www.colorkinetics.com/support/downloads.
3. Using the Layout Plan, assign the fixture to a layout position in the installation.
4. Using a weatherproof label, identify the fixtures installation position based on the Layout Plan. Place the identifying label in an inconspicuous location noting the order or placement in the installation. This step not only minimizes installation mistakes, but aids in post-installation light shows programming.

Installing the Power/Data Supply

Following the Layout Plan, install the power/data supplies according to state and local codes. Refer to the PDS-150e or PDS-60 24V Installation Guides for complete instructions.

WARNING: Ensure that the power is off before wiring or connecting fixtures to the power/data supply. Failure to do so can result in serious injuries or death.

CAUTION: Never lengthen the ColorBlast 6 cable. Doing so will result in property damage and void the warranty.

Addressing the Lights

IMPORTANT: Before you begin the installation, consider the scope of your lighting application and installation. Your ColorBlast 6 is set to light address one (1) at the factory. If your application requires other addresses, set the light addresses using one of the following addressing tools:

ZAPI: Use Color Kinetics Zapi to set the DMX address for each fixture or set all fixtures to the same DMX address. Refer to the Zapi User Guide for step-by-step addressing instructions.

SAS (SERIAL ADDRESSING SOFTWARE): Use a PC with iPlayer 2, or a PC with Smart Jack 3 to address the fixtures. Download SAS and instructions from www.colorkinetics.com/support/downloads.

LIGHT SYSTEM MANAGER (LSM) OR VIDEO SYSTEM MANAGER (VSM): Use LSM or VSM software to discover and address all fixtures via Ethernet. For detailed information on using LSM or VSM, see the LSM or VSM User's Guides.

NOTE: All of these tools can be used to address light fixtures either pre-installation or post-installation (to save time).

NOTE: For applications using multiple, daisy-chained power supplies, you can address all lights in the chain by attaching Zapi to the first power supply in the series.

Setting Individual Addresses

Using the Serial Number mode of Zapi 1.5 or SAS, address each fixture attached to a power supply or a series of connected power supplies individually.

1. With power disconnected, connect up to six ColorBlast 6 fixtures to the power/data supply.
2. Attach the DMX interface (Zapi, iPlayer 2, or Smart Jack 3) to the DMX IN port on the power/data supply.
3. Connect power to the power/data supply.
4. Use Zapi or SAS to set the light address for each serial number.
5. Disconnect power and then disconnect the addressed ColorBlast 6 fixture(s).
6. Repeat steps 1 through 5 for all remaining fixtures.
7. After all fixtures are addressed, disconnect the DMX interface.

Setting the Same Address to Multiple Lights

Using Zapi 1.5, address all fixtures attached to a power supply or multiple, daisy-chained power supplies.

1. With power disconnected, connect up to six ColorBlast 6 fixtures to the power/data supply.
2. Attach the Zapi to the DMX IN port on the power/data supply.
3. Connect power to the power/data supply.
4. Use Zapi to set the light addresses. All ColorBlast 6 fixtures connected to the power/data supply are addressed simultaneously.
NOTE: If you are using SAS, you must input each serial number (address) separately.
5. Disconnect the DMX interface.

Installing ColorBlast 6 Fixtures

This fixture must be installed by a qualified electrician in accordance with NEC and relevant local codes for Class 2 power sources.

ColorBlast 6 can be installed indoors or outdoors. When mounting on walls and ceilings, use an electrical junction box rated for your application.

Through-Base Cable Assembly

For all installations where the cable must go through the canopy base, follow the directions below to prevent cable damage and to create a water-tight seal for outdoor installations.

1. Screw the liquid-tight fitting into the canopy base. The O-ring must be seated against the canopy opening to ensure a water-tight seal.
2. Insert the fixture cable through the dome nut. Loosen the dome nut if necessary. Pull the cable through the fitting. Leave enough cable above the fitting to ensure full fixture head rotation.
3. Tighten dome nut to seal the cable. After 24 hours, tighten the dome nut again to ensure proper sealing force and water-tight seal. (See Fig. 1.)

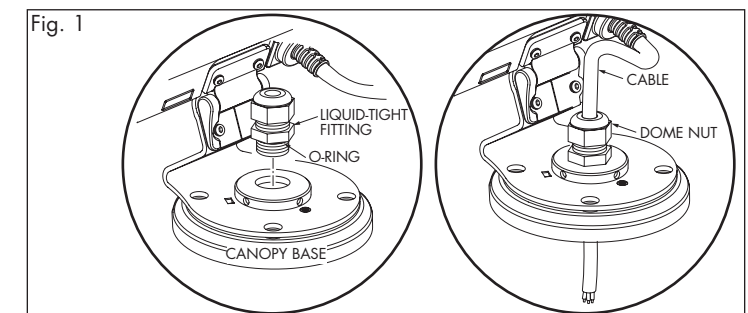

Indoor: Wall or Ceiling Mount

1. Ensure the junction box is located within 60 feet of the fixture.
Pull fixture leader cable through the junction box.

NOTE: If you do not exceed the maximum accumulated cable length of 400 feet for all fixtures attached to a single PDS-150e, then you can splice additional cable between the junction box and the power/data supply, as long as the cable length between the power/data supply and the fixture does not exceed 150 feet.

2. Using the provided screws, attach the mounting bracket of ColorBlast 6 to the junction box. (See Fig. 2.)

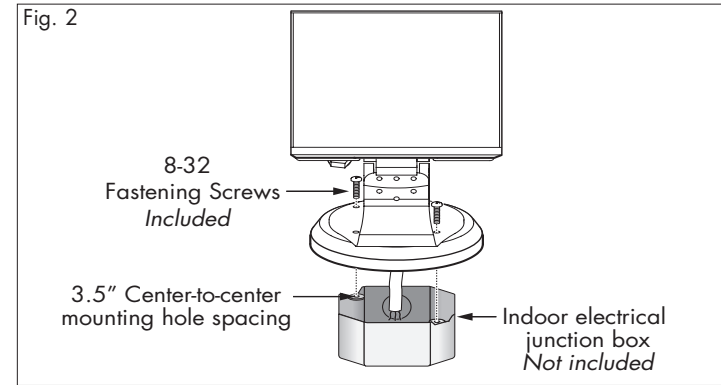

Outdoor: Wall or Ceiling Mount

For outdoor installations, ColorBlast 6 must be used with an outdoor-rated junction box and the gasket must be used to ensure a watertight seal.

1. Ensure that the junction box is located within 60 feet of the power/data supply. Thread the leader cable through provided gasket. Pull fixture leader cable through the junction box.

NOTE: If you do not exceed the maximum accumulated cable length of 400 feet for all fixtures attached to a single PDS-150e, then you can splice additional cable between the junction box and the power/data supply, as long as the cable length between the power/data supply and the fixture does not exceed 150 feet.

2. Using the provided screws, attach the mounting bracket of ColorBlast 6 to the outdoor rated junction box. (See Fig. 3.)

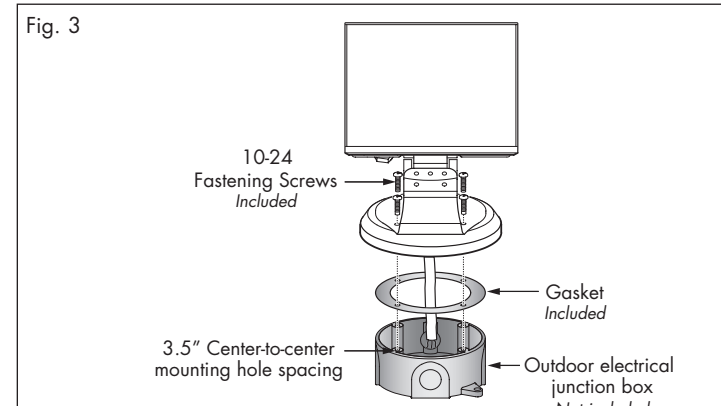

Floor Mount

When used indoors, ColorBlast 6 can be mounted without a junction box. Ensure that the fixture sits flush to the surface and use mounting hardware suitable for the mounting surface.

Positioning Fixtures

Rotate the light fixture to the desired position. Using the provided hex key, tighten the set screws located on the base to lock in place. Tilt the fixture to the desired angle and tighten the set screws located on the front of housing to lock. See Fig. 4 for location of set screws.

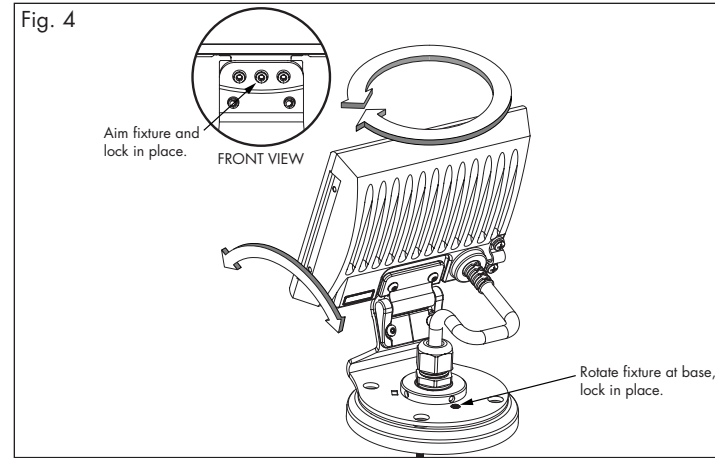

NOTE: For permanent installations, use thread locker to prevent loosening.

Attaching Safety Cable

1. Locate the safety cable bracket on rear of ColorBlast 6. (See Fig. 5.)

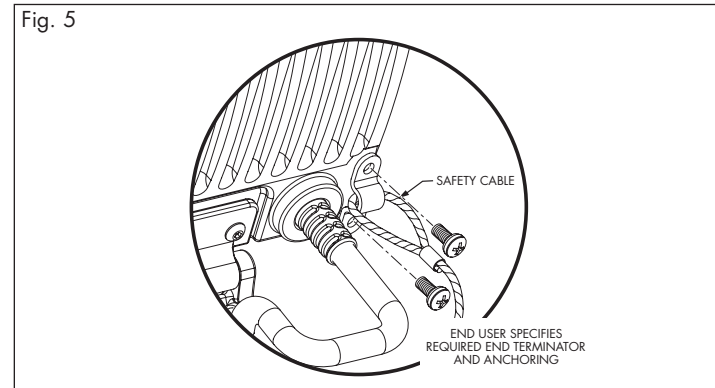

2. Remove the two screws that attach the cable bracket to the fixture. Loop the safety cable over the cable bracket and reattach to the fixture. Add thread locker to further secure the hardware.
3. Attach the safety cable to the mounting surface. Consult a Structural Engineer and refer to applicable standards for your specific application to determine the proper method for mounting the safety cable to the installation surface.

Safety cables used in the installation must meet the following minimal requirements:

- MATERIAL:** 316 Stainless Steel
- SIZE:** 5/64-inch (0.78-inch nominal diameter) or larger, minimum break load must be greater than 400 pounds. Maximum diameter is 3/16-inch.
- CONSTRUCTION:** 7 x 7 (49 wires) preformed stranded
- END TERMINATIONS:** Determined by installer and/or owner
- MOUNTING METHOD:** Determined by installer or owner

Making Electrical Connections

ColorBlast 6 is compatible with Color Kinetics power/data supplies.

WARNING: Ensure that the power is off before wiring or connecting fixtures to the power/data supply. Failure to do so can result in serious injuries or death.

Connecting Power

ColorBlast 6 requires 24 VDC. After installing the light fixtures, connect the power/data cable to the power/data supply.

Each PDS-150e supports six ColorBlast 6 fixtures. Wire one fixture per terminal block. Each PDS-60 24V supports two ColorBlast 6 fixtures. Fig. 6 shows ColorBlast 6 fixtures connected to PDS-150e. Fig. 7 – Fig. 9 show fixtures connected to PDS-60 24V power/data supplies.

CAUTION: Do not overload the power/data supply. Doing so will result in product failure and void the warranty.

CAUTION: You must use the cable provided with the unit. Use of other cables may result in light failure and void the warranty.

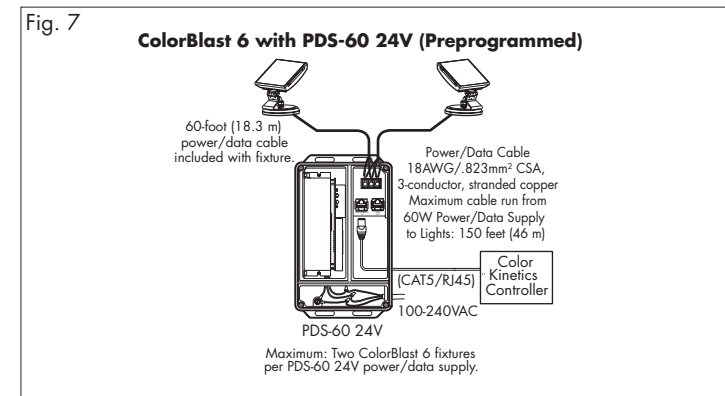
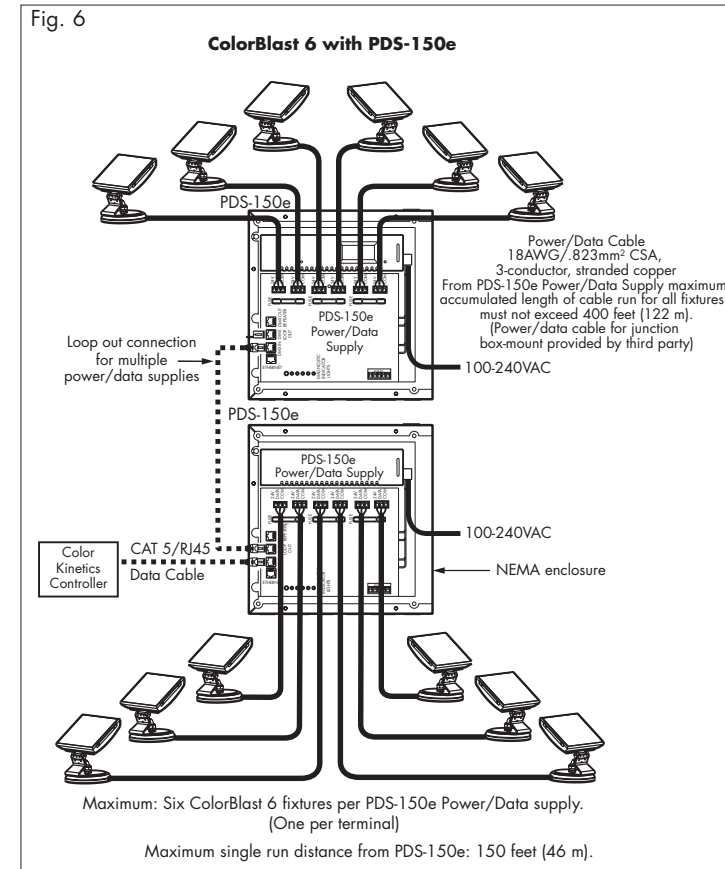

Fig. 8 ColorBlast 6 with PDS-60 24V (DMX Control)

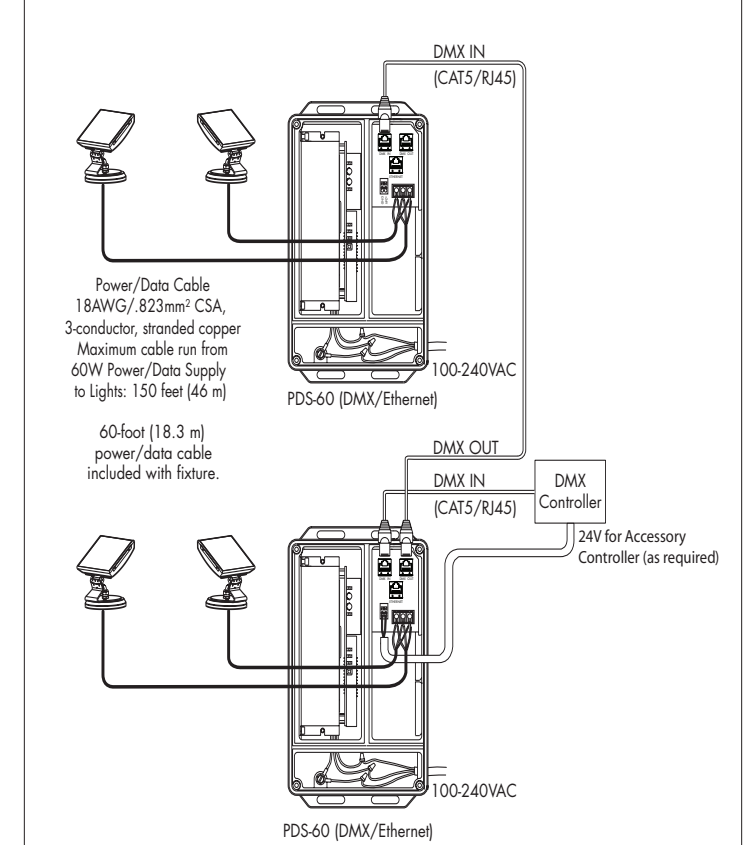
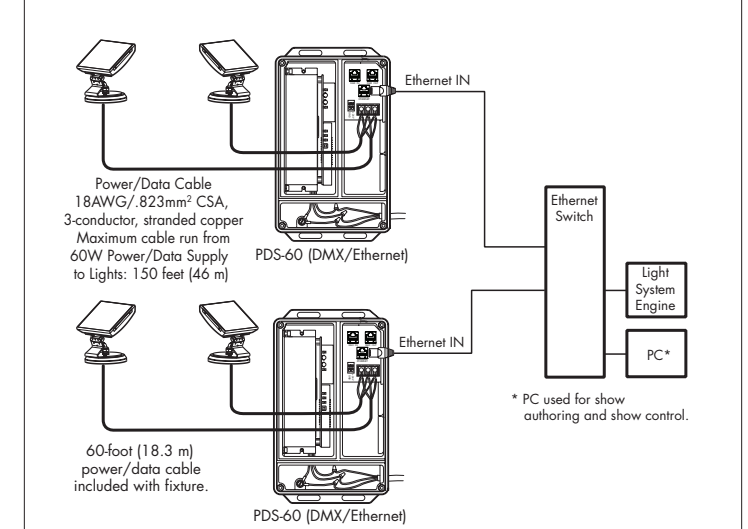

Fig. 9 ColorBlast 6 with PDS-60 24V (Ethernet Control)



NOTE: Each light must receive power directly from a power supply. You cannot daisy chain power from one ColorBlast 6 to another.

The ColorBlast 6 cable contains three color-coded wires. (See Fig. 10.)

- Black = Common
- White = Data
- Red = +24 VDC

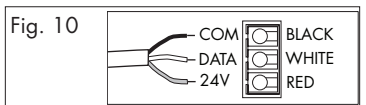

IMPORTANT INFORMATION

Strobe Warning

There is some anecdotal evidence that strobe lighting may induce epileptic symptoms in certain susceptible individuals, although no associated product warnings have been issued by United States government according to the Food and Drug Administration.

If strobe lights are used, some international regulatory agencies¹ recommend keeping flicker rates at or below four flashes per second (as less of the flicker-sensitive population will then be at risk of an attack). This flicker rate applies only to the overall output of any group of lights in direct view. However, when more than one strobe light is used, the flashes should be synchronized. End users should also consider issuing a warning, alerting audience or viewers to the presence of strobe lighting.

Temperature Monitoring

For protection from extreme temperatures, ColorBlast 6 has been designed with a temperature monitoring feature. If operating temperatures rise to an unsafe level, a compensation circuit is triggered and the ColorBlast 6 operation is interrupted causing the lights to turn dull red. After 30 minutes the lights will auto-cycle and return to full intensity.

To prevent additional power shut-downs, determine the cause of the overheating and correct the problem.

If any problems occur during usage, unplug the product immediately and call or email: Color Kinetics Technical Support Group:

1-888-FULL RGB or 617-423-9999 or support@colorkinetics.com.

COLORBLAST 6 SPECIFICATIONS

COLOR RANGE	16.7 million (24 bit) additive RGB colors Continuously variable intensity output range
SOURCE	High intensity power LEDs
BEAM ANGLE	10° clear lens, 22° ground lens
HOUSING	Die Cast Aluminum in black or white finish
CONNECTORS	Unified power and data cable
LISTINGS	UL/cUL, CE
PROTECTION RATING	IP66
DATA INTERFACE	Color Kinetics data interface system
CONTROL	Color Kinetics full line of controllers or other DMX512 (RS485) compatible when using Color Kinetics power/data supply
POWER REQUIREMENT	24VDC
POWER CONSUMPTION	25W Max. at full intensity (full RGB)
POWER SUPPLY	PDS-150e - Maximum of 6 fixtures per supply PDS-60 24V - Maximum of 2 fixtures per supply
TEMPERATURE RANGE	-40°F to 122°F (-40°C to 50°C) operating temperature -4°F to 122°F (-20°C to 50°C) starting temperature

LED SOURCE LIFE

In traditional lamp sources, lifetime is defined as the point at which 50% of the lamps fail. This is also termed Mean Time Between Failure [MTBF]. LEDs are semiconductor devices and have a much longer MTBF than conventional sources. However, MTBF is not the only consideration in determining useful life. Color Kinetics uses the concept of useful light output for rating source lifetimes. Like traditional sources, LED output degrades over time (lumen depreciation) and this is the metric for SSL lifetime.

LED lumen depreciation is affected by numerous environmental conditions such as ambient temperature, humidity, and ventilation. Lumen depreciation is also affected by means of control, thermal management, current levels, and a host of other electrical design considerations. Color Kinetics systems are expertly engineered to optimize LED life when used under normal operating conditions. Lumen depreciation information is based on LED manufacturers’ source life data as well as other third party testing. Low temperatures and controlled effects have a beneficial effect on lumen depreciation. Overall system lifetime could vary substantially based on usage and the environment in which the system is installed.

Temperature and effects will affect lifetime. Color Kinetics rates product lifetime using lumen depreciation to 50% of original light output. When the fixture is running at room temperature using a color wash effect, the range of lifetime is in the range of 80,000-100,000 hours. This is LED manufacturers’ test data. High output is defined as any LED device that is 1/2 watt or above. For more detailed information on source life, please see www.colorkinetics.com/lifetime.

WARRANTY

This product is sold pursuant to CK’s Standard Terms and Conditions (the “T&Cs”) which may be found at http://colorkinetics.com/howtobuy/buy/terms and which contain important provisions, including, among others, Limited Warranty, exclusions and limitations on CK’s liability for damages, and restrictions on the remedies that are available to you.

¹ [Guide to Health, Safety and Welfare at Pop Concerts and Similar Events](#), HMSO Publications (UK)